

## GV-7.5・10

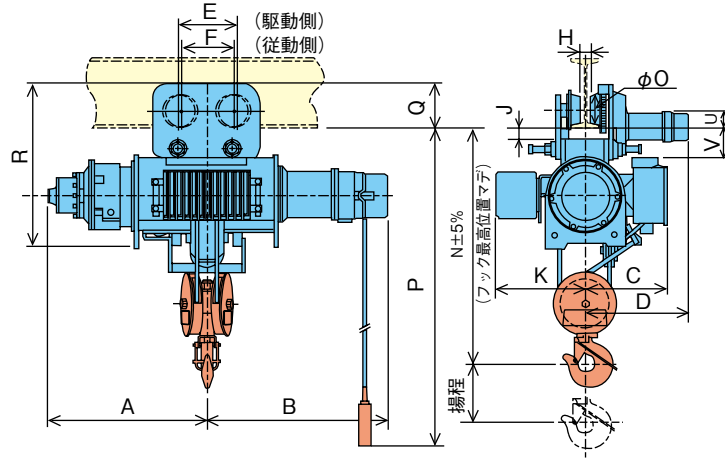

## GV-15・20

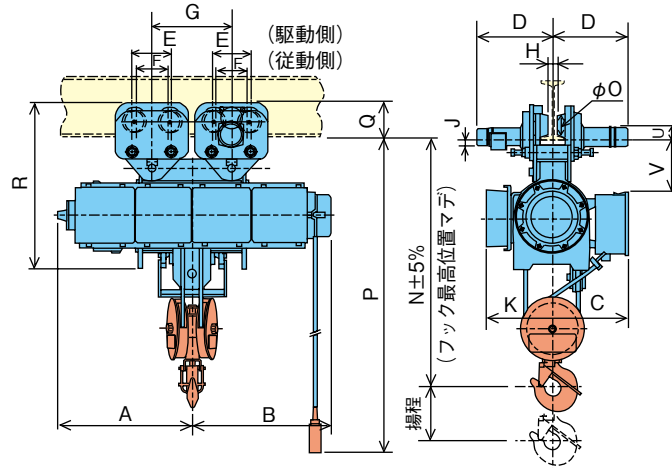

形名	GV-7.5				GV-10				GV-15				GV-20													
	MM	MMV	MHM	MHMV	MM	MMV	MHM	MHMV	MM	MMV	MHM	MHMV	MHM	MHMV												
容量 (t)	7.5				10				15				20													
揚程 (m)	8		12		8		12		8		12		12													
概略寸法 (mm)	A	881		1006		949		1074		1045		1195		1243												
	B	1004		1129		959		1084		1085		1235		1235												
	C	458				493				558				583												
	E	300				328				300				328												
	F	270				296				270				296												
	G	-				-				620		800		800												
	K	497				528				430				455												
	N	1270				1450				1930				2090												
	O	173				193				173				193												
P	8000		12000		8000		12000		8000		12000		12000													
R	903				988				1268				1398													
最小屈曲半径 (m)	5.0	12.5	5.0	12.5	5.0	12.5	5.0	12.5	直線				直線													
概略質量 (kg)	900		970		1250		1350		2200		2350		2700													
フックロック質量 (kg)	80				100				190				280													
I形鋼関連寸法 (mm)	D	H	J	Q	U	V	D	H	J	Q	U	V	D	H	J	Q	U	V								
適用 I 形鋼	400×150×125	578	60	49	254	117	150	604	54	49	279	141	210	-				-								
	450×175×13	590	85	49	254	117	150	617	78	49	279	141	210	590	85	49	254	117	150	347	616	81	49	279	141	451
	600×190×13	598	100	50	253	116	151	624	94	50	278	140	211	598	100	50	253	116	151	348	624	96	50	278	140	452

(注) 適用の I 形鋼の □ 色部分は、標準仕様を示します。