

GV-1/2・1・2・2.8・3・5

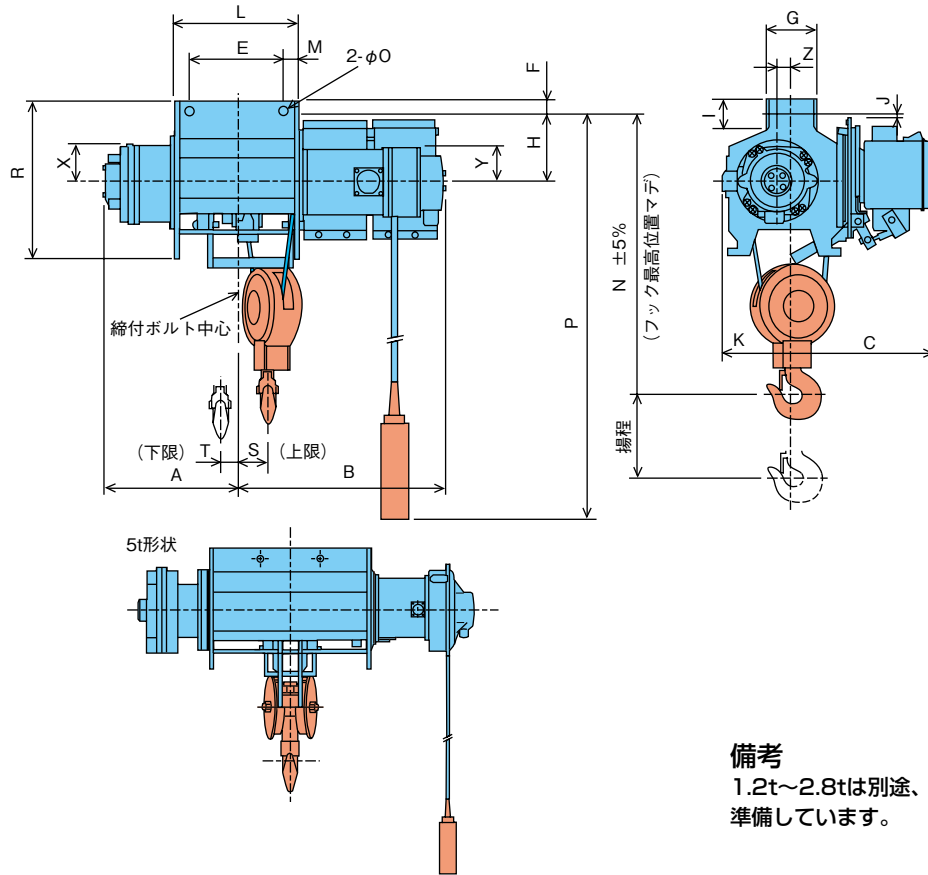

備考

1.2t～2.8tは別途、専用締付けボルトを準備しています。

形名	GV-1/2		GV-1		GV-2		GV-2.8 (3)		GV-5		
	K	KH	K	KH	K	KH	K	KH	K	KH	
容量 (t)	1/2		1		2		2.8(3)		5		
揚程 (m)	6	12	6	12	6	12	6	12	8	12	
概略寸法 (mm)	A	315	486	321	508	352	509	373	542	685	810
	B	433	473	518	551	577	605	658	689	830	955
	C	324		345		383		408		410	
	E	170	230	230	230	230	230	230	230	290	
	F	28	33	33		38		43		60	61
	G	140	117	117		151		176		229	
	H	155		160		177		215		225	
	I	75	78	63		67		80		105	106
	J	3		12		21		89		114	
	K	151		167		190		216		226	
	L	283	493	298	518	323	508	323	523	725	975
	M	32	42	34	67	47	75	46	77	-	-
	N	570		670		800		965		905	
	O	20	24	24		33		33		38	
	P	6000	12000	6000	12000	6000	12000	6000	12000	8000	12000
	R	328	333	373		425		518		546	
	S	50	93	71	105	58	101	60	97	-	-
T	58	123	42	119	49	113	47	115	-	-	
X	87		107		140		172		205		
Y	83		105		150		150		206		
Z	20		36		30		30		30		
概略質量 (kg)	100	110	145	160	230	255	325	360	580	650	
フックブロック質量 (kg)	4.5		7.5		15		27		42		

(注) G-1/2の押ボタン吊下げ位置は巻上減速部側となります。