

## GV-7.5・10

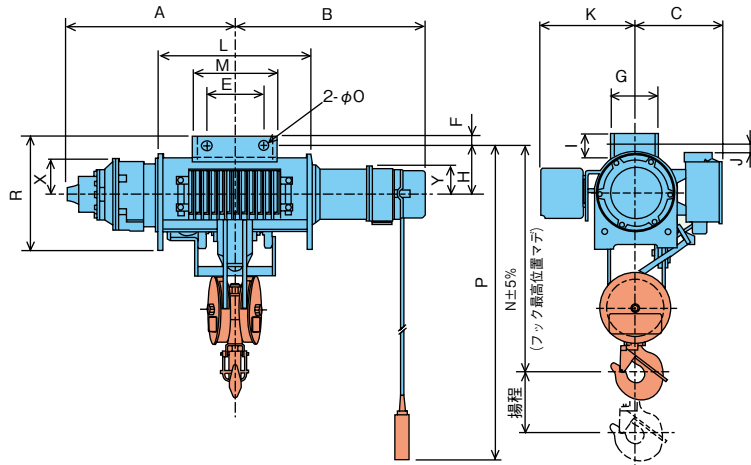

## GV-15・20

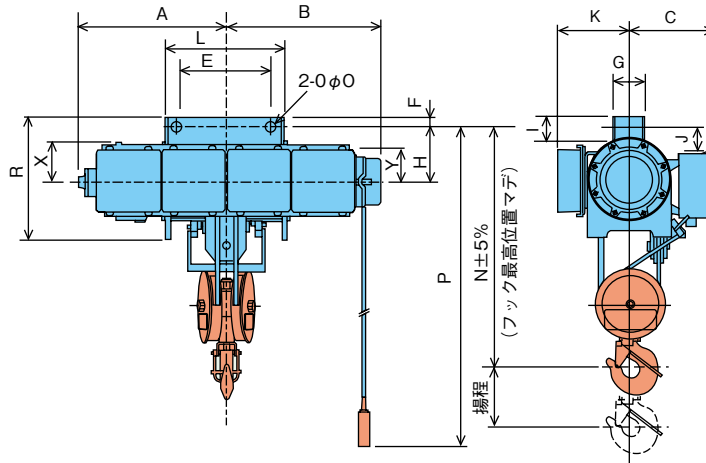

形名	GV-7.5		GV-10		GV-15		GV-20	
	K	KH	K	KH	K	KH	KH	
容量 (t)	7.5		10		15		20	
揚程 (m)	12		12		12		12	
概略寸法 (mm)	A	881	1006	949	1074	1045	1195	1243
	B	1004	1129	959	1084	1085	1235	1235
	C	458		493		558		583
	E	300		320		620	800	800
	F	55		60		80		100
	G	252		252		225		225
	H	255		290		365		410
	I	120		120		178		217
	J	45		100		73		118
	K	497		528		430		455
	L	796	1046	786	1036	831	1131	1131
	M	440		460		-		-
	N	1165		1380		1680		1800
	O	47		53		78		103
P	8000	12000	8000	12000	8000	12000	12000	
R	600		660		845		935	
X	188		218		292		322	
Y	152		220		220		220	
概略質量 (kg)	700	770	1050	1150	1500	1650	2000	
フックブロック質量 (kg)	80		100		190		280	