

## GV-7.5・10

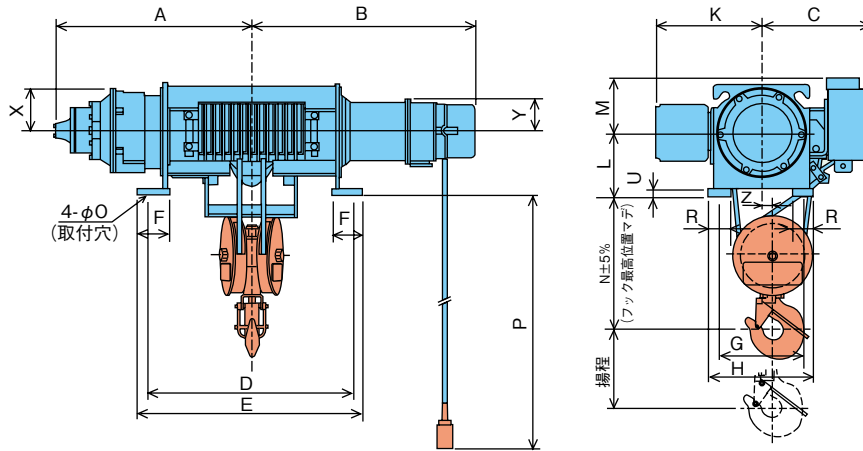

## GV-15・20・30

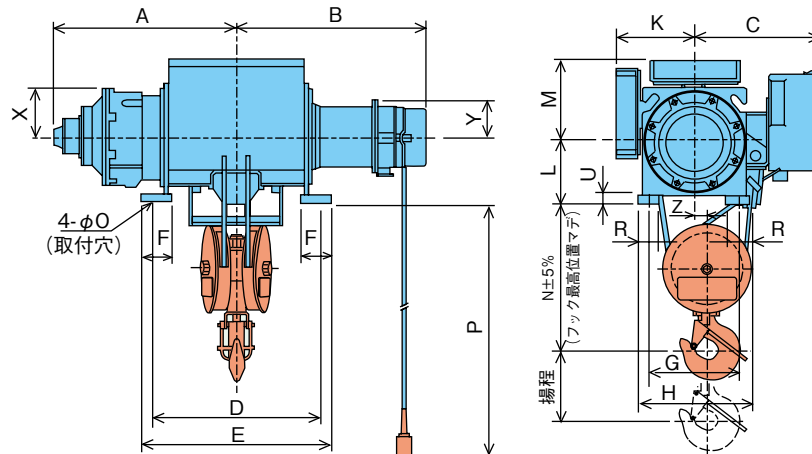

形名	GV-7.5		GV-10		GV-15		GV-20	GV-30	
	F	FH	F	FH	F	FH	FH	FH	
容量 (t)	7.5		10		15		20	30	
揚程 (m)	8	12	8	12	8	12	12	12	
概略寸法 (mm)	A	881	1006	949	1074	1045	1195	1243	1456
	B	1004	1129	959	1084	1085	1235	1235	1284
	C	493		531		633		663	713
	D	920	1170	920	1170	960	1260	1260	1380
	E	1010	1260	1010	1260	1080	1380	1380	1480
	F	140		150		170		170	200
	G	370		370		500		500	620
	H	470		490		630		640	770
	K	497		500		458		470	457
	L	290		310		370		395	435
	M	245		265		443		468	522
	N	580		670		810		870	960
	O	35		35		47		47	54
	P	8000	12000	8000	12000	8000	12000	12000	12000
	R	100		120		130		140	150
U	31		35		41		41	49	
X	188		218		275		308	320	
Y	152		220		220		220	220	
Z	50		53		70		70	80	
概略質量 (kg)	700	770	1050	1150	1500	1650	2000	3300	
フックブロック質量 (kg)	80		100		190		280	380	