

# GVH (10t・15t・20t・30t)

## GVH-10・15・20・30

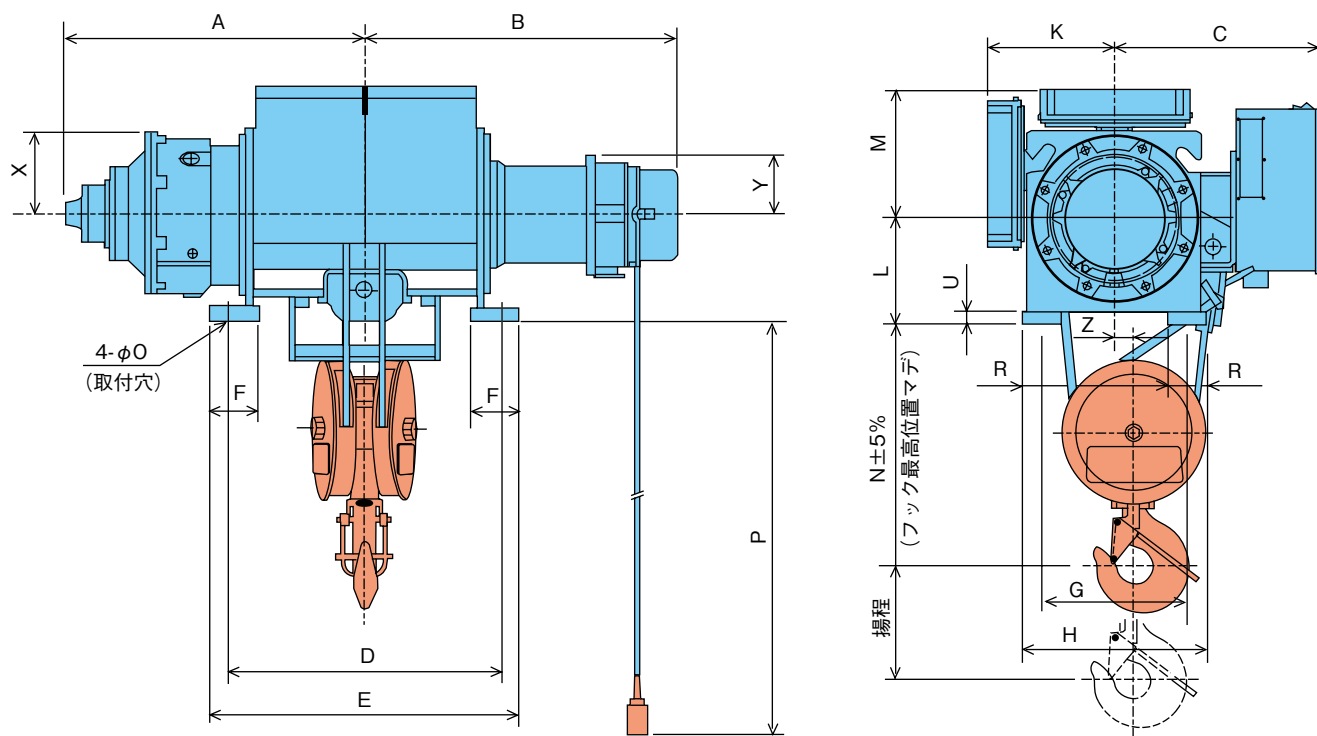

形名	GVH-10		GVH-15		GVH-20	GVH-30	
	F	FH	F	FH	FH	FH	
容量 (t)	10		15		20	30	
揚程 (m)	8		8		12	12	
概略寸法 (mm)	A	949	1074	1045	1195	1243	1456
	B	1055	1180	1205	1355	1355	1405
	C	553		633		663	713
	D	920	1170	960	1260	1260	1380
	E	1010	1260	1080	1380	1380	1480
	F	150		170		170	200
	G	370		500		500	620
	H	490		630		640	770
	K	414		458		470	567
	L	310		370		395	435
	M	443		443		468	522
	N	670		810		870	960
	O	35		47		47	54
	P	8000	12000	8000	12000	12000	12000
	R	120		130		140	150
U	35		41		41	49	
X	302 (抵抗まで)		218		275	320	
Y	220		220		220	220	
Z	53		70		70	80	
概略質量 (kg)	1200	1300	1700	1850	2200	3500	
フックブロック質量 (kg)	100		190		280	380	