

## G2-7.5・10・15・20

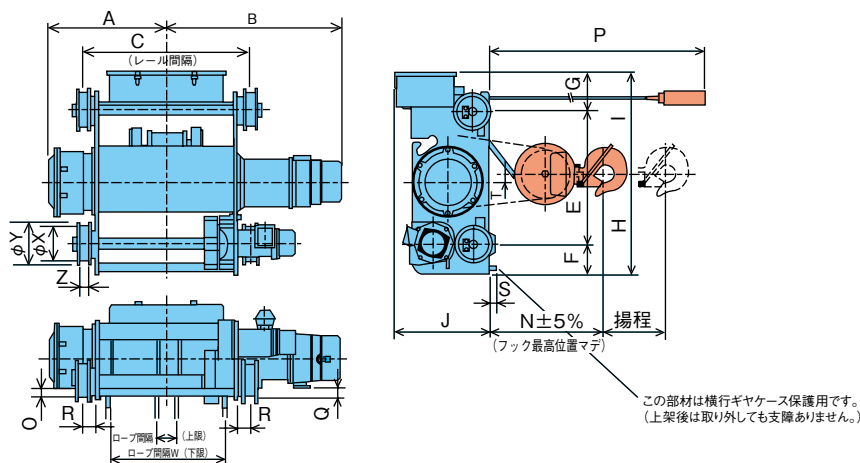

## G2-30

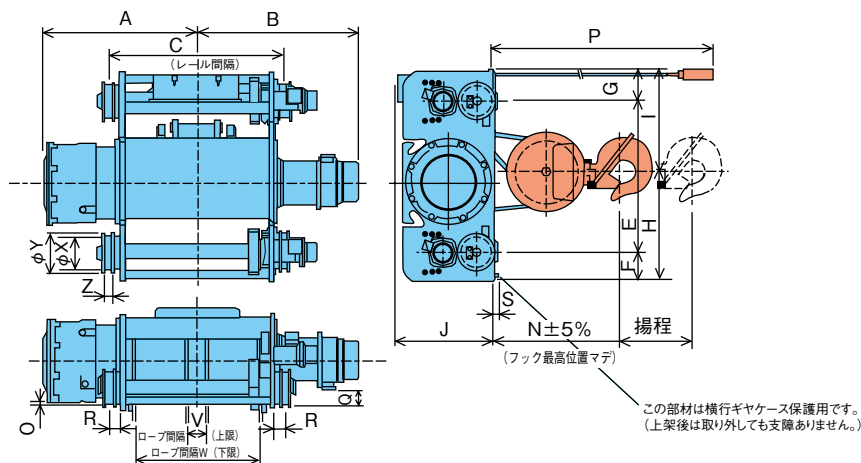

形名	G2-7.5		G2-10		G2-15		G2-20	G2-30	
	WM	WHM	WM	WHM	WM	WHM	WHM	WHM	
容量 (t)	7.5		10		15		20	30	
揚程 (m)	8	12	8	12	8	12	12	12	
概略寸法 (mm)	A	722	847	772	897	852	1002	1052	1262
	B	1004	1129	959	1084	1085	1235	1235	1285
	C	950	1200	950	1200	1000	1300	1300	1400
	E	760		840		1000		1045	1190
	F	170		170		220		220	220
	G	223		233		243		248	246
	H	570		613		760		790	850
	I	583		630		703		723	802
	J	543		543		743		748	763
	N	630		710		860		910	1020
	O	40		38		30		32	15
	P	8000	12000	8000	12000	8000	12000	12000	12000
	Q	75		30		85		120	115
	R	77		82		84		84	89
	S	45		55		55		55	45
	T	50		53		70		70	80
V	105	80	100	100	110	135	125	150	
W	660	910	620	870	660	960	945	990	
X	190		190		250		250	250	
Y	225		225		285		285	285	
Z	52		52		58		58	73	
概略質量 (kg)	900	980	1250	1360	1900	2100	2500	3600	
フックロック質量 (kg)	80		100		190		280	380	
適用レール	15kgレールまたは44mm角鋼				22kgレールまたは50mm角鋼			37kgレールまたは65mm角鋼	